

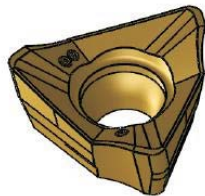

HEAD®-Master

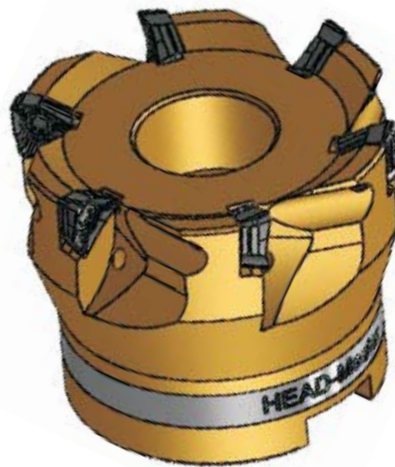
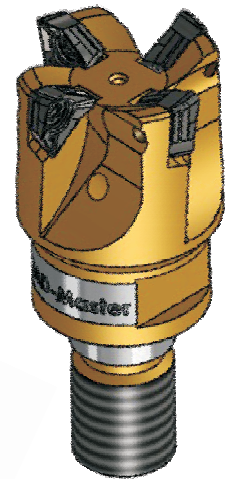
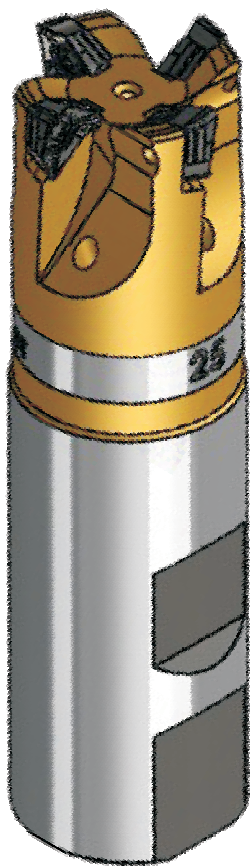

THE TOOLS 1010-TH

Der Universelle Taschenfräser
The universal Plange Milling

Inhaltsverzeichnis Index

1010-TH	Taschenfräser 90° Plange milling cutter 90°	Seite 3 Page 3
1012-TH	Taschenfräser 90° Plange shoulder milling cutter 90°	Seite 3 Page 3
1014-TH	Tascheneinschraubfräser 90° Plange shoulder milling cutter 90°	Seite 4 Page 4
1016-TH	Taschenfräser 90° Plange milling cutter 90°	Seite 4 Page 4
1018-TH	Taschenfräser 90° Plange milling cutter 90°	Seite 5 Page 5
5125	Spannwerkzeuge Clamp Tools	Seite 5 Page 5
	Wendeplatten Inserts	Seite 5 Page 5
	THE Tool Set´s Promotion	Seite 6 Page 6
	HM - Qualitäten HM - Grades	Seite 7 Page 7
	Technische Daten Technical Datas	Seite 7 Page 7

Taschenfräser 90° Plange milling 90°

Ausführung: Taschenfräser zylindrisch 90°, mit Innenkühlung
Lieferumfang: ohne Wendeschneidplatte, ohne Schraubendreher
Anwendung: Nuten- und Eckfräsen, Helixfräsen und universelle Einsatzmöglichkeit

Execution: Plange milling cutter cylindrical 90°, with inner coolant
Delivery: without insert, without screwdriver
Application: Groove- and shoulder milling, Helical Milling and universal application

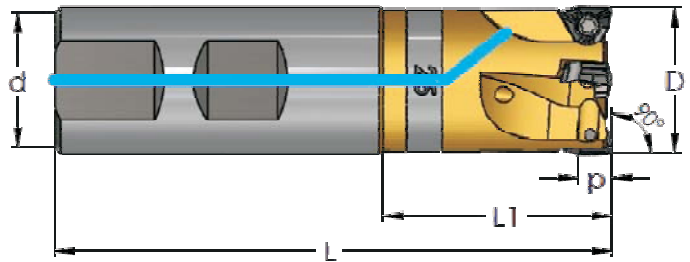
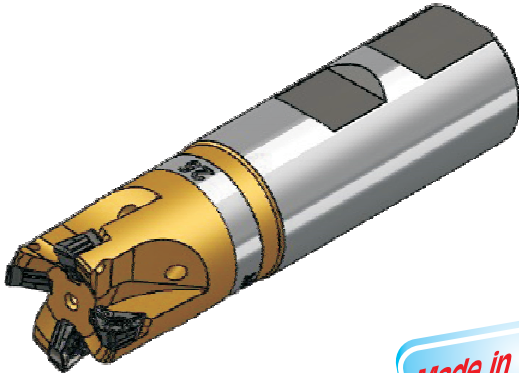

Made in Germany

NEU / NEW



Bestell-Nr./Order No.	Abmessungen - Dimension (mm)						Wendeplatte insert	Wpl.-schraube insert screw	Torxschlüssel key
	D	d	L	L1	p	z			
1010-TH									
W-W D18	18	20	90	40	4,5	2	TPKT 0803...	M-VT 25	M-BT 08
W-WL D18	18	20	150	40	4,5	2			
W-W D20	20	20	90	40	4,5	3			
W-WL D20	20	20	150	40	4,5	3			
W-W D25-3	25	25	95	40	4,5	3			
W-WL D25-3	25	25	150	40	4,5	3			
W-W D25	25	25	95	40	4,5	4			
W-W D25	25	25	150	40	4,5	4			
W-W D32	32	25	95	40	4,5	5			
W-WL D32	32	25	150	40	4,5	5			
W-W D40	40	32	110	40	4,5	6			

W-W = Kühlmittelbohrung / W-W = coolant bores

Bestellbeispiel / Orderexample: 1010-W-W D20

Ausführung: Taschenfräser zylindrisch 90°, mit Innenkühlung
Lieferumfang: ohne Wendeschneidplatte, ohne Schraubendreher
Anwendung: Nuten- und Eckfräsen, Helixfräsen und universelle Einsatzmöglichkeit

Execution: Plange milling cutter cylindrical 90°, with inner coolant
Delivery: without insert, without screwdriver
Application: Groove- and shoulder milling, Helical Milling and universal application

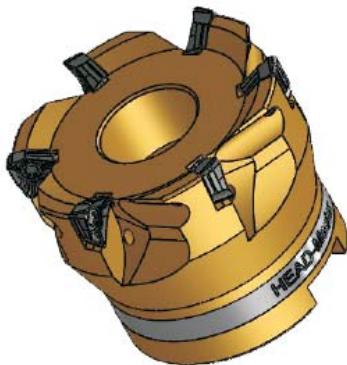

Made in Germany

NEU / NEW

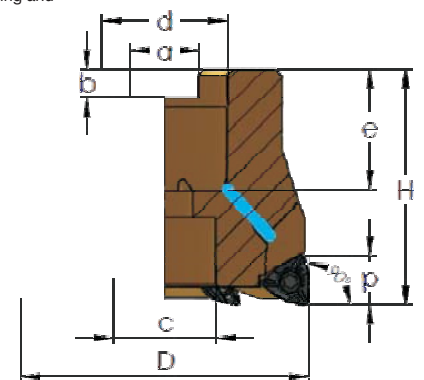

Bestell-Nr./Order No.	Abmessungen - Dimension (mm)									Wendeplatte insert	Wpl.-schraube insert screw	Torxschlüssel key
	D	d	c	e	a	b	H	p	z			
1012-TH												
M-W D32	32	16		21	8,4	5,6	40	4,5	5	TPKT 0803...	M-VT 25	M-BT 08
M-W D40	40	22	17	21	10,4	6,3	40	4,5	6			
M-W D50	50	22	17	21	10,4	6,3	40	4,5	6			
M-W D63	63	22	17	21	10,4	6,3	40	4,5	8			
M-W D80	80	27	20	22	12,4	7	50	4,5	10			

M-W = Kühlmittelbohrung / M-W = coolant bores

Bestellbeispiel / Orderexample: 1012-M-W D32

Taschenfräser 90° Plange milling 90°

Ausführung: Taschenfräser zylindrisch 90°, mit Innenkühlung
Lieferumfang: ohne Wendeschneidplatte, ohne Schraubendreher
Anwendung: Nuten- und Eckfräsen, Helixfräsen und universelle Einsatzmöglichkeit

Execution: Plange milling cutter cylindrical 90°, with inner coolant
Delivery: without insert, without screwdriver
Application: Groove- and shoulder milling, Helical Milling and universal application

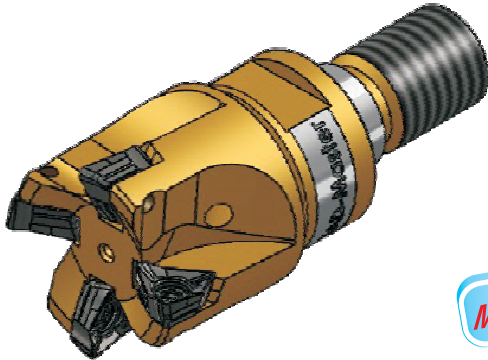

Made in Germany

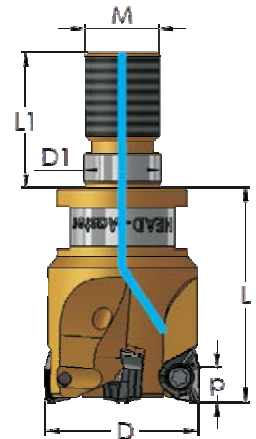

NEU / NEW



Bestell-Nr./Order No.	Abmessungen - Dimension (mm)							Wendep platte insert	Wpl.-schraube insert screw	Torxschlüssel key
1014-TH	D	p	L	L1	M	D1	z			
E-W D18	18	4,5	30	20	M8	8,5	2	TPKT 0803...	M-VT 25	M-BT 08
E-W D20	20	4,5	30	20	M10	10,5	3			
E-W D25-3	25	4,5	35	22	M12	12,5	3			
E-W D25	25	4,5	35	22	M12	12,5	4			
E-W D32	32	4,5	43	24	M16	17,0	5			
E-W D42	42	4,5	68	24	M16	17,0	6			

E-W = Kühlmittelbohrung / E-W = coolant bores
 Verlängerungen siehe Katalog Werkzeug- & Formenbau
 Extensions are in our Mouldmill catalogue

Bestellbeispiel / Orderexample: 1014-E-W D20

Ausführung: Taschenfräser zylindrisch 90°, mit Innenkühlung
Lieferumfang: ohne Wendeschneidplatte, ohne Schraubendreher
Anwendung: Nuten- und Eckfräsen, Helixfräsen und universelle Einsatzmöglichkeit

Execution: Plange milling cutter cylindrical 90°, with inner coolant
Delivery: without insert, without screwdriver
Application: Groove- and shoulder milling, Helical Milling and universal application

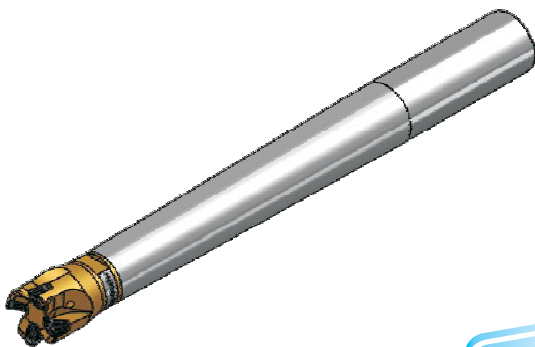

Made in Germany

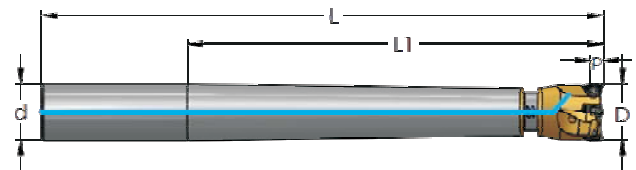

Bestell-Nr./Order No.	Abmessungen - Dimension (mm)						Wendep platte insert	Wpl.-schraube insert screw	Torxschlüssel key
1016-TH	D	d	L	L1	p	z			
W-WXL D18	18	16	195	140	4,5	2	TPKT 0803...	M-VT 25	M-BT 08
W-WXL D20	20	20	230	170	4,5	3			
W-WXL D25-3	25	25	250	185	4,5	3			
W-WXL D25	25	25	250	185	4,5	4			
W-WXL D32	32	32	265	195	4,5	5			
W-WXL D42	42	32	288	218	4,5	6			

W-W = Kühlmittelbohrung / W-W = coolant bores

Bestellbeispiel / Orderexample: 1016-W-WXL D20

Taschenfräser 90° Plunge milling cutter 90°

Ausführung: Taschenfräser zylindrisch 90°, mit Innenkühlung
Lieferumfang: ohne Wendeschneidplatte, ohne Schraubendreher
Anwendung: Nuten- und Eckfräsen, Helixfräsen und universelle Einsatzmöglichkeit

Execution: Plunge milling cutter cylindrical 90°, with inner coolant
Delivery: without insert, without screwdriver
Application: Groove- and shoulder milling, Helical Milling and universal application

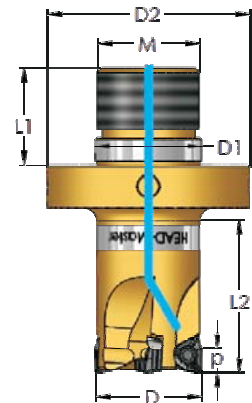
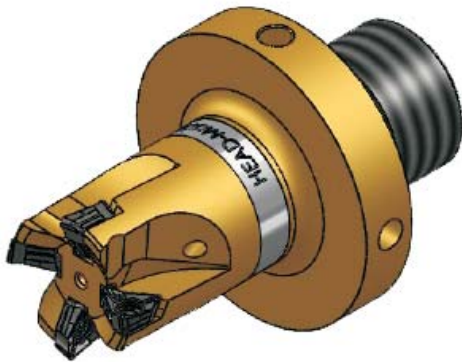

NEU / NEW

Made in Germany



Bestell-Nr./Order No. 1018-TH	Abmessungen - Dimension (mm)									Wendepatte insert	Wpl.-schraube insert screw	Torxschlüssel key
	M	D	D1	D2	p	L	L1	L2	z			
<input type="checkbox"/> E-W D18	M24x1.5	18	25	48	4,5	50	23	36	2	TPKT 0803...	M-VT 25	M-BT 08
<input type="checkbox"/> E-W D20	M24x1.5	20	25	48	4,5	50	23	36	3			
<input type="checkbox"/> E-W D25-3	M24x1.5	25	25	48	4,5	50	23	36	3			
<input type="checkbox"/> E-W D25	M24x1.5	25	25	48	4,5	50	23	36	4			
<input type="checkbox"/> E-W D32	M24x1.5	32	25	48	4,5	50	23	36	5			
<input type="checkbox"/> E-W D40	M24x1.5	40	25	48	4,5	50	23	36	6			
<input type="checkbox"/> E-W D50	M24x1.5	50	25	48	4,5	50	23	36	6			
<input type="checkbox"/> E-W D63	M24x1.5	63	25	48	4,5	50	23	36	8			

E-W = Kühlmittelbohrung / E-W = coolant bores
 = Auf Anfrage lieferbar / delivery on request

Bestellbeispiel / Orderexample: 1018-E-W D20

Spannwerkzeuge clamp tools

Bestellnummer/Order-No. 5125	Spannwerkzeuge mit innerer Kühlmittelzuführung Clamp tools with inner coolant	
DIN 69871 AD+B	SK 40	SK 50
MAS-BT	BT 40	BT 50
HSK	HSK-A63	



Bestellbeispiel / Orderexample: 5125 SK 40

Wendepplatten Inserts

Form Figure	Abmessungen Dimensions					Bezeichnung Designation	Beschichtete Sorten- coated grades						
	l	d	s	d1	r		Cermet		Unbeschichtete Sorten- uncoated				
							CT54	K10	MTM10	PT28	PT35	KTE20	PT28
	8,00	8,00	2,40	2,50	0,50	TPCKT 0803 PDSR...	■	■	■	■	■	■	■
	8,00	8,00	2,40	2,50	1,20	TPCKT 080312 PDSR...	□	□	□	□	□	■	■
	8,00	8,00	2,40	2,50	1,60	TPCKT 080316 PDSR...	□	□	□	□	□	■	■
	8,00	8,00	2,40	2,50	2,00	TPCKT 080320 PDSR...	□	□	□	□	□	■	■

■ Lieferbar in stock □ auf Anfrage on request

THE Tool Set - 1010-TH



beinhaltet / consists of:

- 1 Stück** 1010-TH W-W D20 (Z=3)
1 Piece 1010-TH W-W D20 (Z=3)
- 1 Stück** 1010-TH W-W D25 (Z=4)
1 Piece 1010-TH W-W D25 (Z=4)
- 20 Stück** TPKT 0803 PDSR PTV28
20 Pieces TPKT 0803 PDSR PTV28
- 1 THE Tool Werttaler**
1 THE Tool Mark

*Lieferung der THE Tool Set's ohne Werkzeugbestückung
*Delivery of the THE Tool Set's without toolassembling

Einlösen des Werttalers:

Bei Rücksendung des THE Tool Talers
kann 1 St. Taschenfräser 1010-TH
Ø20 oder Ø25 oder Ø32 eingelöst werden.

Cash in of the mark:

In return of the THE Tool mark
can 1 pc plange mill 1010-TH
Ø20 or Ø25 or Ø32 be redeemed.



THE Tool Set - 1012-TH



beinhaltet / consists of:

- 1 Stück** 1012-TH M-W D50 (Z=6)
1 Piece 1012-TH M-W D50 (Z=6)
- 20 Stück** TPKT 0803 PDSR PTV28
20 Pieces TPKT 0803 PDSR PTV28
- 1 THE Tool Werttaler**
1 THE Tool Mark

*Lieferung der THE Tool Set's ohne Werkzeugbestückung
*Delivery of the THE Tool Set's without toolassembling

Einlösen des Werttalers:

Bei Rücksendung des THE Tool Talers
kann 1 St. Taschenaufsteckfräser 1012-TH
Ø40 oder Ø50 oder Ø63 eingelöst werden.

Cash in of the mark:

In return of the THE Tool mark
can 1 pc plange mill 1012-TH
Ø40 or Ø50 or Ø63 be redeemed.



ISO

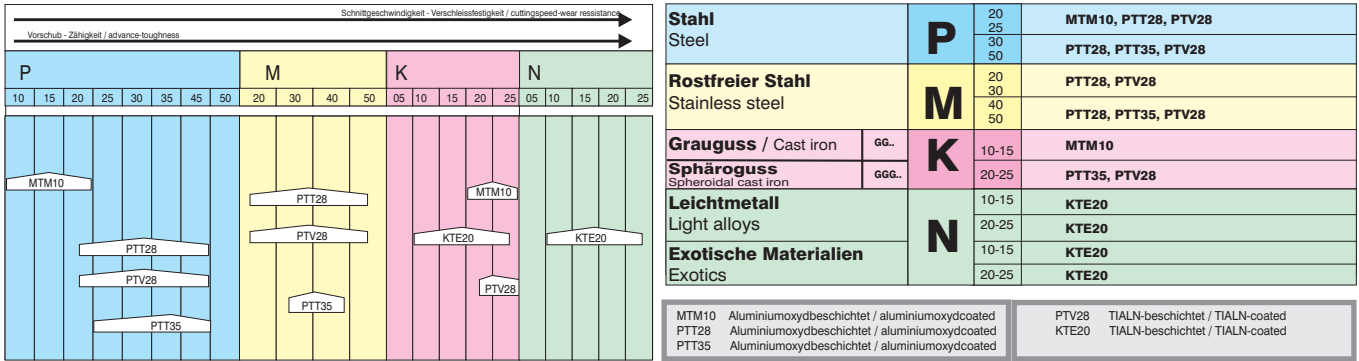

Werkzeugtypen Tool-Types

		1010 1012 1014 1016 1018	
		vc Schnittgeschwindigkeit	fz Zahnvorschub
Einfachbearbeitungs-Kohlenstahl <i>Easy to work carbon steel</i>	PTT28, PTV28 PTT35	120-180	0,08-0,12
Flussstahl - Edelstahl <i>Cast steel - alloyed steel</i>	PTT28, PTV28 PTT35	110-150	0,08-0,12
Werkzeugstahl <i>Steel for tools</i>	PTT28, PTV28 PTT35	110-150	0,08-0,12
Martensit-Ferriter Rostfreier Stahl AISI400 <i>Martensitic and ferritic stainless steel AISI400</i>	PTT28, PTV28 PTT35	110-170	0,08-0,12
Austenitischer Rostfreier Stahl - Serie AISI300 <i>Austenitic stainless steel AISI300</i>	PTT28, PTV28 PTT35	90-140	0,08-0,12
Grauguss <i>Gray cast iron</i>	MTM10	120-180	0,08-0,12
Sphäroguss <i>Spheroidal cast iron</i>	PTT35, PTV28	120-180	0,08-0,12
Eisenfreies Material Kupfer - Gelbguss <i>Non ferrous material -copper, brass</i>	KTE20	120-160	0,08-0,12
Aluminiumlegierung <i>Aluminium alloy</i>	KTE20	250-400	0,08-0,12

Die o.g. Daten sind als Empfehlungswerte zu betrachten.
The above data are approximate.

MAIER
HEAD·Master

THE TOOLS
1010

1
THE TOOL

MAIER
HEAD·Master

THE TOOLS
2010

1
THE TOOL

MAIER
HEAD·Master

THE TOOLS
2050/2060

MAIER
HEAD·Master

THE TOOLS

FACE & CHAMFER MILLING
Senk- & Faswerkzeuge

MAIER
HEAD·Master

THE TOOLS

Werkzeug- & Formenbau
MOULDMILL

MAIER
HEAD·Master

THE TOOLS F-2010
Der Universelle Helixfräser
The universal Helical milling



Oberpiebing
 Dorfstraße 14
 D-94330 Salching

Tel.: +49 (0)9426 - 80 26 50
 Fax: +49 (0)9426 - 80 26 51

e-mail: info@maier-tools.de
www.maier-tools.com